

0.25-20 Mounting Hardware.

Reactor and Din Rail Plate and Hardware Shipped Together, Unassembled.

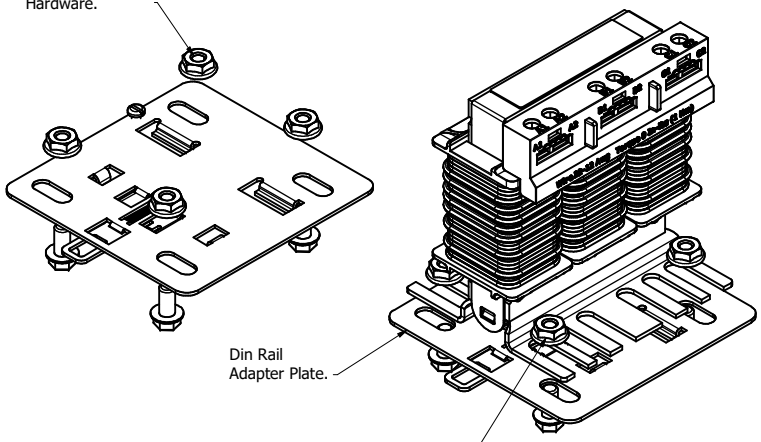

Din Rail Adapter Plate.

Hardware Assembly Torque. 66 in-lbs (7.5 N-m)

480 Rated Voltage, 690 Max Voltage, High Z, Impedance.

Part Number	Horsepower (HP)	Motor Amps (A)	Maximum Amps (A)	Inductance (uH) +/-10%	Weight (LBS)	Losses (W)
KDRAA1H2DR	2	3.40	3.8	10800	3.4	33
KDRAA2H2DR	3	4.80	5.4	7650	3.4	42
KDRAA6H2DR	4	6.20	7.6	5930	3.8	50
KDRAA3H2DR	5	7.60	8.2	4840	4.0	66
KDRAA3H2DR	5 1/2	8.20	8.2	4840	4.0	74
KDRAA4H2DR	7 1/2	11	12	3060	4.4	70
KDRAA5H2DR	10	14	14	2330	4.6	97.7

208/ 240 Rated Voltage, 690 Max Voltage, High Z, Impedance.

Part Number	Horsepower (HP)	Motor Amps (A)	Maximum Amps (A)	Inductance (uH) +/-10%	Weight (LBS)	Losses (W)
KDRAA28H2DR	3	10.6	11	1618	3	44.6

600 Rated Voltage, 690 Max Voltage, High Z, Impedance.

Part Number	Horsepower (HP)	Motor Amps (A)	Maximum Amps (A)	Inductance (uH) +/-10%	Weight (LBS)	Losses (W)
KDRAA46H2DR	1 1/2	2.40	3.2	19100	3.6	26
KDRAA43H2DR	2	2.70	3.4	17000	3.4	30
KDRAA44H2DR	3	3.90	4.5	11800	3.3	47
KDRAA57H2DR	4	4.90	6.0	9380	3.9	48
KDRAA58H2DR	5	6.10	6.8	7530	3.8	44
KDRAA58H2DR	5 1/2	6.60	6.8	7530	3.8	47

480 Rated Voltage, 690 Max Voltage, Low Z, Impedance.

Part Number	Horsepower (HP)	Motor Amps (A)	Maximum Amps (A)	Inductance (uH) +/-10%	Weight (LBS)	Losses (W)
KDRAA6L2DR	4	6.20	7.6	3560	3.4	39
KDRAA3L2DR	5	7.60	8.2	2900	3.4	45
KDRAA3L2DR	5 1/2	8.20	8.2	2900	3.4	49
KDRAA4L2DR	7 1/2	11.0	11.6	2000	3.6	63
KDRAA5L2DR	10	14	14	1580	3.7	77.7

208/ 240 Rated Voltage, 690 Max Voltage, Low Z, Impedance.

Part Number	Horsepower (HP)	Motor Amps (A)	Maximum Amps (A)	Inductance (uH) +/-10%	Weight (LBS)	Losses (W)
KDRAA28L2DR	3	10.6	12	971	3.4	42

600 Rated Voltage, 690 Max Voltage, Low Z, Impedance.

Part Number	Horsepower (HP)	Motor Amps (A)	Maximum Amps (A)	Inductance (uH) +/-10%	Weight (LBS)	Losses (W)
KDRAA52L2DR	3	3.90	4.8	7100	3.9	30
KDRAA57L2DR	4	4.90	7.6	5630	3.3	30
KDRAA58L2DR	5	6.10	7.6	4520	3.4	39
KDRAA58L2DR	5 1/2	6.60	7.6	4520	3.4	44
KDRAA48L2DR	7 1/2	9.00	9.6	3100	3.6	57
KDRAA49L2DR	10	11	11	2350	4.2	52.6

Set Screw, Used To Prevent Assembly From Sliding On Din Rail.

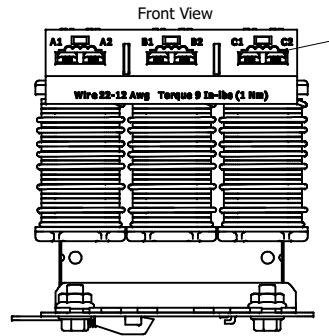
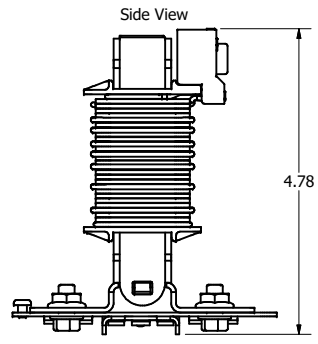
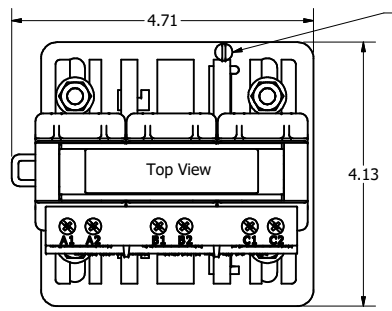

Wire Range: 22-12 AWG.
Torque : 9 In-lbs (1 Nm)

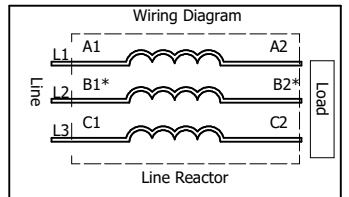

* For single phase applications, use coils A and C, Isolate terminals B1 and B2.

- Notes: 1. UL file number: cULus Listed File E116124.
- 2. KDR Drive Reactors Comply With The Thermal and Altitude Standards Set Forth by NEMA ST20-1992.
- 3. KDR IOM Manual Part Number 30895
- 4. NEC Current For 208/240 Volts, Horsepower Based On 208 Volts
- 5. Material(s) Shall be RoHS Compliant
- 6. Reactor and Din Rail Plate and Hardware Shipped Together, Unassembled.
- 7. Customer Is Responsible For Installation To Meet All National And Local Electrical Codes.

THE INFORMATION AND DESIGNS CONTAINED IN THIS DRAWING ARE CONFIDENTIAL AND THE PROPRIETARY PROPERTY OF ALLIED MOTION TECHNOLOGIES INC. AND ITS SUBSIDIARIES. NEITHER THIS DESIGN NOR ANY INFORMATION CONTAINED IN THIS DRAWING MAY BE REPRODUCED OR DISCLOSED TO OTHERS WITHOUT THE EXPRESS WRITTEN CONSENT OF ALLIED MOTION TECHNOLOGIES INC. AND ITS SUBSIDIARIES.				TOLERANCES (EXCEPT AS NOTED) DECIMAL .XX ± .25 .XXX ± .10 FRACTIONAL ± 1/32 ANGULAR ± 1°				W132N10611 (Rev 11/20) German town, WI 53022 © 2023 TCI, LLC An Official Motors Company KDR AA Frame, Terminal Block Din Rail, Inductor Drawing DWN BY: DSW DATE: 12/07/2017 SCALE: 1:1.5 DRAWN BY: 107475DG REVISION DATE BY	
F	6232	Remove KDRAA47L2							
F	6232	Remove KDRAA9H2L2	4/6/2023	DSW					
E	49L2DR	Inductance changed	10/1/22	JSG					
D	5455, 9L, 9L1, 1H, 46H, 43H	Weight update	1/14/2021	DSW					
NO		REVISION							